

EXV-CB, EXP and SXV-CB Technical Data High Lift Pallet Trucks/Electric Forklift Truck

EXV-CB 06

EXV-CB 10/Li-Ion

EXV-CB 12/Li-Ion

EXV-CB 16/Li-Ion

EXP 14

EXP 16

EXP 20

SXV-CB 10/Li-Ion





Distinguishing marks			STILL	STILL	STILL	STILL	STILL	STILL	STILL	STILL
			EXV-CB 06	EXV-CB 10/Li-Ion	EXV-CB 12/Li-Ion	EXV-CB 16/Li-Ion	EXP 14	EXP 16	EXP 20	SXV-CB 10/Li-Ion
1.1	Manufacturer									
1.2	Manufacturer's type designation									
1.3	Drive		Electric	Electric	Electric	Electric	Electric	Electric	Electric	Electric
1.4	Operator type		Pedestrian	Pedestrian	Pedestrian	Pedestrian	Pedestrian	Pedestrian	Pedestrian	Stand-on
1.5	Rated capacity/rated load	Q	kg	600	1000	1200	1600	1400	1600	2000
1.6	Load centre distance	c	mm	500	500	500	500	600	600	600
1.8	Load distance	x	mm	107	107	107	107	696 ^{1,3}	686 ^{1,3}	660 ^{1,3}
1.9	Wheel base	y	mm	914	1264	1264	1626	1406	1406	1129 (1145) ³
Weights	2.1	Service weight incl. battery		kg	1725 ⁵	1861 ⁵	1885 ⁵	2085 ⁵	1516	1556
	2.2	Axle load, laden	drive end/load end	kg	560/1765 ⁵	635/2226 ⁵	550/2535 ⁵	710/2975 ⁵	1187/1749	1183/1972
	2.3	Axle load, unladen	drive end/load end	kg	950/775 ⁵	1099/762 ⁵	1100/785 ⁵	1295/790 ⁵	1072/444	1086/470
Tyres/chassis	3.1	Tyres			Polyurethane	Polyurethane	Polyurethane	Polyurethane	Polyurethane	Polyurethane
	3.2	Tyre size	drive end	mm	Ø 230 x 100	Ø 230 x 100	Ø 230 x 100	Ø 230 x 100	Ø 230 x 90	Ø 230 x 90
	3.3	Tyre size	load end	mm	Ø 4x 85 x 105	Ø 4x 85 x 105	Ø 4x 85 x 105	Ø 4x 85 x 105	Ø 85 x 85 (Ø 85 x 60) ²	Ø 85 x 85 (Ø 85 x 60) ²
	3.4	Support castor size		mm	-	-	-	-	Ø 100 x 40	Ø 100 x 40
	3.5	Number of wheels (x = driven)	drive end/load end		1x + 4	1x + 4	1x + 4	1x + 4	1x + 1/2 (1x + 1/4) ²	1x + 1/2 (1x + 1/4) ²
	3.6	Track width	drive end	b ₁₀	mm	-	-	-	534	534
Dimensions	4.1	Tilt of mast/fork carriage	forward/backward	α/β	°	-	1/6	1/6	-	-
	4.2	Height	mast lowered	h ₁	mm	See mast table	See mast table	See mast table	See mast table	See mast table
	4.3	Free lift		h ₂	mm	See mast table	See mast table	See mast table	See mast table	See mast table
	4.4	Lift		h ₃	mm	See mast table	See mast table	See mast table	See mast table	See mast table
	4.5	Height	mast extended	h ₄	mm	See mast table	See mast table	See mast table	See mast table	See mast table
	4.7	Height of overhead guard		h ₆	mm	-	-	-	-	-
	4.9	Height drawbar in driving position	min./max.	h ₁₄	mm	740/1230	740/1230	740/1230	740/1230	800/1250
	4.10	Height of wheel arms		h ₈	mm	-	-	-	-	80
	4.15	Fork height, lowered		h ₁₃	mm	67	67	67	67	50
	4.19	Overall length		l ₁	mm	2511	2861	2861	3223	2071
	4.20	Length to face of forks		l ₂	mm	1311	1661	1661	2023	921 ^{3,4}
	4.21	Overall width		b ₁	mm	790	790	790	790	1170/1370/1570
	4.22	Fork dimensions		s/e/l	mm	45/100/1200	45/100/1200	45/100/1200	45/100/1200	35/100/1150
	4.24	Fork carriage width		b ₃	mm	1000	1000	1000	1000	820/980
4.25	Distance of forks	min./max.	b ₅	mm	225/926	225/926	225/926	225/926	400/720 // 400/880	
4.26	Distance between wheel arms		b ₄	mm	-	-	-	-	860/1060/1260	
4.32	Ground clearance, centre of the wheel base		m ₂	mm	38	38	38	38	30	
4.33	Aisle width for pallets 1000 x 1200 crossways		A _{st}	mm	2786	3136	3136	3296	2588 ⁴	
4.34	Aisle width for pallets 800 x 1200 lengthways		A _{st}	mm	2874	3224	3224	3384	2559 ⁴	
4.35	Turning radius		W _a	mm	1510	1860	1860	2220	1715 ⁴	
4.37	Length across wheel arms		l ₇	mm	-	-	-	-	1739	
Performance data	5.1	Travel speed	laden/unladen	km/h	5/6	5/6	5/6	5/6	6/6	6/6
	5.2	Lift speed	laden/unladen	m/s	0.15/0.3	0.15/0.3	0.15/0.3	0.15/0.3	0.16/0.30	0.15/0.30
	5.3	Lowering speed	laden/unladen	m/s	0.45/0.35	0.45/0.35	0.45/0.35	0.45/0.35	0.40/0.35	0.31/0.31
	5.8	Max. gradeability kB 5	laden/unladen	%	4/4	4/4	4/4	4/4	8/23	8/23
5.10	Service brake				Electromagnetic	Electromagnetic	Electromagnetic	Electromagnetic	Electromagnetic	
Electric engine	6.1	Drive motor, rating S2 = 60 min		kW	2.3	2.3	2.3	2.3	2.3	2.3
	6.2	Lift motor, rating at S3 = 15%		kW	2.2	3.2	3.2	3.2	3.2	3.2
	6.3	Battery according to DIN 43531/35/36 A, B, C, no			3PzS	3PzS	3PzS	4PzS	3PzS	3PzS
	6.4	Battery voltage/rated capacity K _s		V/Ah	24/375	24/375	24/375	24/400	24/345	24/345
	6.5	Battery weight (±5%, depends on make)		kg	288	288	288	377	288	288
	6.6	Energy consumption according to VDI cycle		kWh/h	0.72	1.19	1.19	1.45	1.14	1.15
Misc.	8.1	Drive control			AC control	AC control	AC control	AC control	AC control	AC control
	8.4	Sound pressure level at driver's ear		dB(A)	63	61	61	61	≤66	≤66

¹ With telescopic and HiLo mast: +26 mm

² With tandem rollers

³ Value with triplex mast

⁴ Without creep speed: +12 mm

⁵ With lateral battery change

⁶ With optional, inclinable fork carriage

⁷ With optional fork tilt, side shifters or fork adjusters: +48 mm

⁸ With optional, inclinable fork carriage and side shifters as well as fork adjusters: 40/100/1150

⁹ Not available in combination with optional inclinable fork carriage, side shifters or fork adjusters

¹⁰ With optional fork tilt, side shifters or fork adjusters: 800 mm

EXV-CB/EXP High Lift Pallet Trucks and SXV-CB Electric Forklift Truck
 Technical Drawings

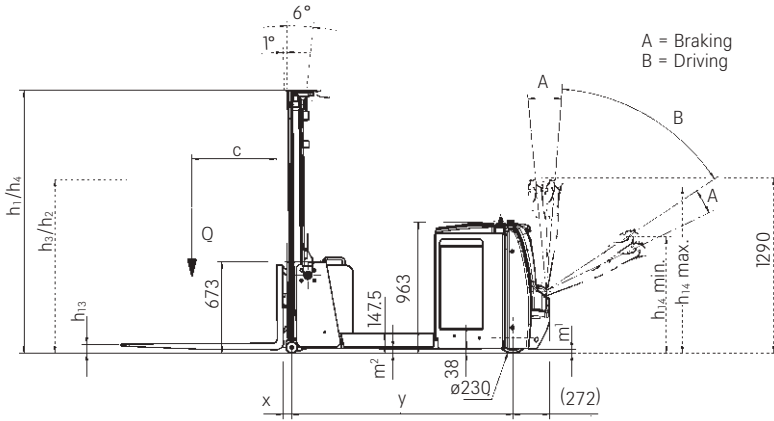

Side view EXV-CB

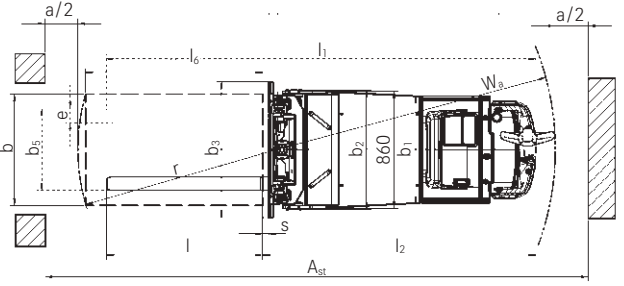

Top view EXV-CB

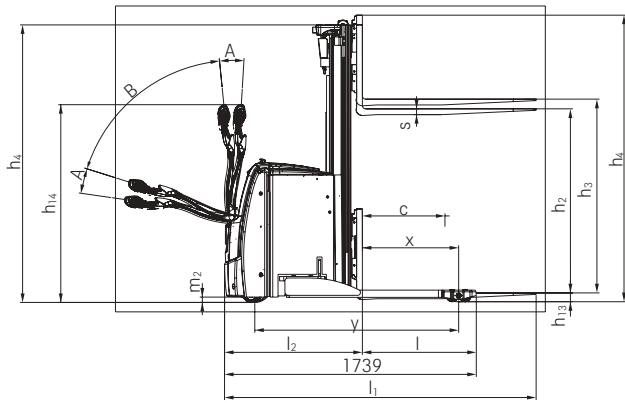

Side view EXP

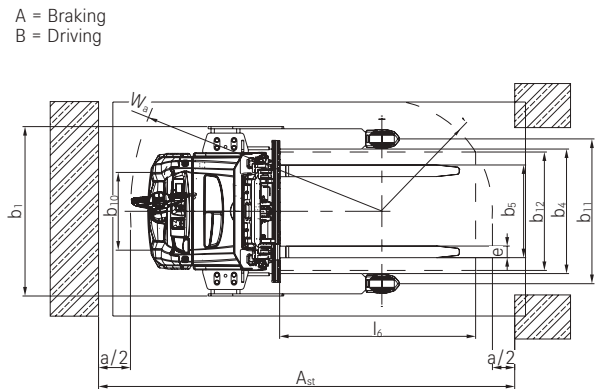

Top view EXP

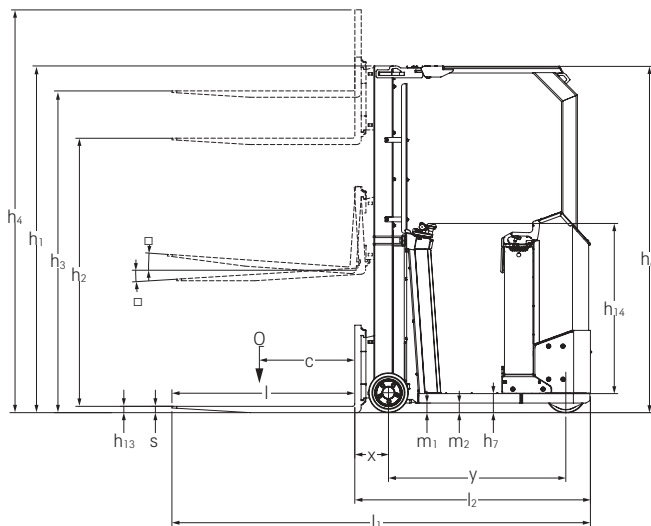

Side view SXV-CB

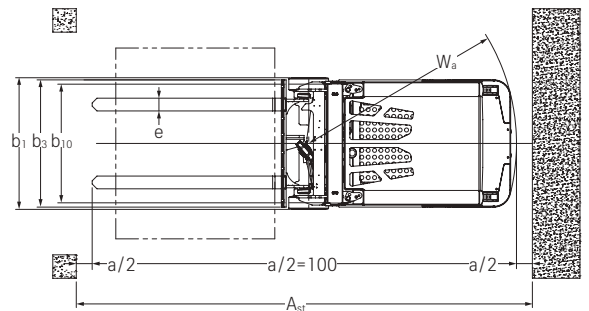

Top view SXV-CB

EXV-CB/EXP High Lift Pallet Trucks and SXV-CB Electric Forklift Truck Mast Tables



			Telescopic				HiLo				Triplex
			mm	mm	mm	mm	mm	mm	mm	mm	mm
EXV-CB 06	Height	h ₁	1515	1765	2015	2215	1440	1690	1940	2140	1690
	Mast height with initial lift applied	h ₁ ¹	1590	1840	2090	2290	-	-	-	-	-
	Free lift	h ₂	150	150	150	150	879	1129	1379	1579	1129
	Lift	h ₃	1924	2424	2924	3324	1924	2424	2924	3324	3516
	Height mast extended	h ₄	2485	2985	3485	3885	2485	2985	3485	3885	4077

			Telescopic				HiLo				Triplex		
			mm	mm	mm	mm	mm	mm	mm	mm	mm		
EXV-CB 10	Height	h ₁	1515	1765	2015	2215	2465	1440	1690	1940	2140	2390	1690
	Mast height with initial lift applied	h ₁ ¹	1590	1840	2090	2290	2540	-	-	-	-	-	-
	Free lift	h ₂	150	150	150	150	150	879	1129	1379	1579	1829	1129
	Lift	h ₃	1924	2424	2924	3324	3824	1924	2424	2924	3324	3824	3516
	Height mast extended	h ₄	2485	2985	3485	3885	4385	2485	2985	3485	3885	4385	4077

			Telescopic				HiLo				Triplex					
			mm	mm	mm	mm	mm	mm	mm	mm	mm	mm	mm	mm	mm	
EXV-CB 12	Height	h ₁	1515	1765	2015	2215	2465	2665	1440	1690	1940	2140	2390	2590	1690	1940
	Mast height with initial lift applied	h ₁ ¹	1590	1840	2090	2290	2540	2740	-	-	-	-	-	-	-	-
	Free lift	h ₂	150	150	150	150	150	150	879	1129	1379	1579	1829	2029	1129	1379
	Lift	h ₃	1924	2424	2924	3324	3824	4224	1924	2424	2924	3324	3824	4224	3516	4266
	Height mast extended	h ₄	2485	2985	3485	3885	4385	4785	2485	2985	3485	3885	4385	4785	4077	4827

			Telescopic				HiLo				Triplex					
			mm	mm	mm	mm	mm	mm	mm	mm	mm	mm	mm	mm	mm	
EXV-CB 16	Height	h ₁	1515	1765	2015	2215	2465	2665	1440	1690	1940	2140	2390	2590	1690	1940
	Mast height with initial lift applied	h ₁ ¹	1590	1840	2090	2290	2540	2740	2740	-	-	-	-	-	-	-
	Free lift	h ₂	150	150	150	150	150	150	879	1129	1379	1579	1829	2029	1129	1379
	Lift	h ₃	1844	2344	2844	3244	3744	4144	1844	2344	2844	3244	3744	4144	3516	4266
	Height mast extended	h ₄	2405	2905	3405	3805	4305	4705	2405	2905	3405	3805	4305	4705	4077	4827

			Telescopic				HiLo				Triplex									
			mm	mm	mm	mm	mm	mm	mm	mm	mm	mm	mm	mm	mm					
EXP 14/16	Height	h ₁	1415 ¹	1665 ¹	1915	2115	2365	2565	2815	1415 ¹	1665 ¹	1915	2115	2365	2565	1665 ¹	1915	2065	2265	2315
	Mast height with initial lift applied	h ₁ ¹	1490	1740	1990	2190	2440	2640	2890	-	-	-	-	-	-	-	-	-	-	-
	Free lift	h ₂ ²	-	-	-	-	-	-	-	776	1026	1276	1476	1726	1926	1026	1276	1426	1626	1676
	Free lift	h ₂ ³	150	150	150	150	150	150	150	-	-	-	-	-	-	-	-	-	-	-
	Lift	h ₃	1844	2344	2844	3244	3744	4144	4644	1844	2344	2844	3244	3744	4144	3516	4266	4716	5316	5466
Height mast extended	h ₄ ⁴	2480	2980	3480	3880	4380	4780	5280	2480	2980	3480	3880	4380	4780	4152	4902	5352	5952	6102	

			Telescopic			HiLo			Triplex		
			mm	mm	mm	mm	mm	mm	mm	mm	mm
EXP 20	Height	h ₁	1915	2115	2365	1915	2115	2365	1665 ¹	1915	2065
	Mast height with initial lift applied	h ₁ ¹	1990	2190	2440	-	-	-	-	-	-
	Free lift	h ₂ ²	-	-	-	1286	1486	1736	1036	1286	1436
	Free lift	h ₂ ³	150	150	150	-	-	-	-	-	-
	Lift	h ₃	2684	3084	3584	2684	3084	3584	3276	4026	4476
Height mast extended	h ₄ ⁴	3310	3710	4210	3310	3710	4210	3902	4652	5102	

			Single		HiLo			Triplex		
			mm	mm	mm	mm	mm	mm	mm	
SXV-CB 10	Height	h ₁	1990 ⁷	2190	1990 ⁵	2190	2390	1990 ⁷	2390	
	Free lift	h ₂	1430 ⁵	1630 ⁵	1430 ⁵	1630 ⁵	1860 ⁵	1430 ⁵	1630 ⁵	1830 ⁵
	Lift	h ₃	1460	1660	2810	3210	3610	4180	4780	5380
	Height mast extended	h ₄	2050 ⁶	2250 ⁶	3470 ⁶	3870 ⁶	4270 ⁶	4840 ⁶	5440 ⁶	6040 ⁶

¹ Mast not recommended for daily battery change

² With load backrest: -537 mm

³ With increased height mast h₁¹

⁴ With load backrest: +537 mm

⁵ With optional fork tilt, side shifters or fork adjusters: -100 mm

⁶ With optional fork tilt, side shifters or fork adjusters: +100 mm

⁷ In combination with low overhead guard

EXV-CB and EXP High Lift Pallet Trucks Detailed Photos



Safety as standard: depending on tiller angle, speed is automatically adapted to the distance between the operator and the truck (OptiSpeed)^{1, 2}



Precise in any situation: thanks to creep speed it is possible to manoeuvre in the most confined of spaces^{1, 2}



High handling capacity up to 2,000 kg and lifting heights of up to 5,466 mm¹



All-rounder: self-supporting and adjustable forks allow the handling of different pallet types^{1, 2}



Innovative battery plug lock enables fast battery replacement, without the risk of jamming²



Safe load handling thanks to mast tilt fitted as standard²

¹ Here e.g. EXP // ² Here e.g. EXV-CB

EXP High Lift Pallet Truck and SXV-CB Electric Forklift Truck Detailed Photos



Hands free: practical storage compartments and a writing pad with built-in clipboard ^{1,2}



Everything in view, all the time: colour display with a range of language-independent symbols shows you all of the important functions at a glance ^{1,2}



Robust overhead guard with steel struts for optimised visibility and increased safety ³



Fast and safe entry and exit thanks to low step height ³



Compact dimensions facilitate working in confined spaces ³

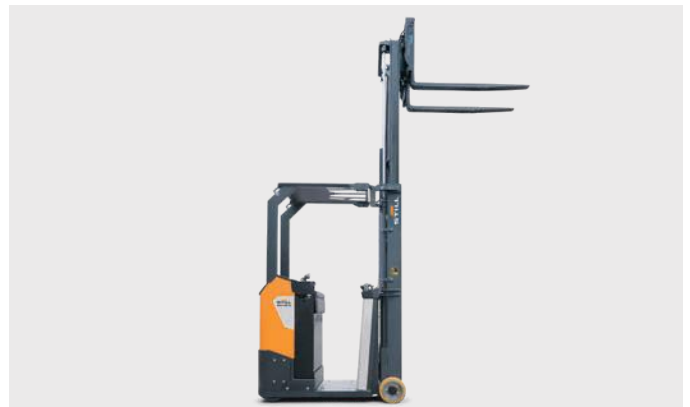

Different loads can be flexibly handled with cantilever forks ³

² Here e.g. EXV-CB // ³ Here e.g. SXV-CB

EXP High Lift Pallet Truck

Flexibility meets innovation

Maximum flexibility: different pallet types and accessory equipment can be used

Optimum utilisation of storage space: high storage compaction due to very high residual load capacity

Everything in view, all the time: colour display with a range of language-independent symbols shows you all of the important functions at a glance



EXP

Stronger and more intelligent than the rest – that is the STILL EXP 14-20 high lift pallet truck. Two of its stand-out features are the enormous residual load capacity and the smart colour display. The latter provides the operator with basic information, the truck status or the battery charge at a glance at all times, and different language-independent symbols provide optimum support in operation. The smart and extremely mobile warehouse organiser moves pallets weighing up to 2,000 kg quickly, safely and reliably. Through self-supporting and adjustable forks different pallets can be used. With optional hydraulic functions accessory equipment can be used as well. An unprecedented reloading of pallets can be achieved thanks to the powerful and low-maintenance motor and the precise control elements, which are

suitable for either left- or right-handed operators. The letters EXP are not only synonymous with quick goods handling, but also with safe goods handling. The optional load capacity display shows what is possible. The curved tiller shape and the sensitive impact plate protect the driver, and the EXP stops automatically when the tiller is released – even on ramps. The OptiSpeed tiller also adjusts the speed of the EXP to the distance from the operator, while the Curve Speed Control system regulates the speed around bends. This high lift pallet truck, which is as strong as it is smart, allows you to always keep your flow of goods safely under control; from transporting loads within the pre-storage area to operating the shelving system.



EXV-CB High Lift Pallet Truck and SXV-CB Electric Forklift Truck Flexibility meets innovation

Secure goods transport: mast tilt for easy and secure handling of load carriers

Maximum flexibility: different pallets and attachments can be used

Optimal manoeuvrability and ergonomics thanks to electrical steering unit and OptiSpeed tiller



EXV-CB

Load lifting easier than ever before: with the EXV-CB high lift pallet truck, you can lift pallets and carriers of any kind. The cantilever forks allow you to expand your functionality using a range of accessories. A lifting capacity of up to 1,600 kg combined with lifting heights up to 4.2 m guarantee optimal storage consolidation and handling capacity. The electrical steering unit and the smart STILL tiller ensure intuitive and equally fatigue-free operation. Proportional valve technology ensures precision right to the fork tips, enabling precise lifting and

lowering and thereby noticeably simplifying load handling. The STILL OptiSpeed tiller guarantees optimal safety and automatically adjusts the driving speed in accordance with the tiller angle. With the web-based FleetManager option, you can easily integrate the EXV-CB into your fleet: Who may use which high lift pallet truck and for which tasks? How is the EXV-CB's capacity being utilised? When was it involved in an accident? All in all, the EXV-CB is as versatile as a Swiss army knife, optimising your workflow from the pre-storage area to the shelves.

A versatile all-rounder: compact dimensions, intuitive operation and outstanding availability ensure a high level of stability and therefore a wide range of potential applications

Manoeuvrability in confined spaces: small turning radius and narrow aisle width

Ergonomic workplace: comfortable driver's seat and fatigue-free load handling thanks to speed-dependent steering without readjusting hand position



SXV-CB

The SXV-CB is a reliable all-rounder for a range of applications. The electric forklift truck is extremely compact and particularly stable when cornering thanks to excellent weight distribution and automatic speed restriction. With its narrow aisle width and small turning radius, it is also extremely manoeuvrable in the tightest of spaces. It can effortlessly lift up to 1,000 kilograms on its cantilever forks. The SXV-CB is user-friendly, and, thanks to its speed-dependant steering, can be controlled with precision and efficiency with minimal effort. There is also the option of integrating a second control panel for added convenience when reversing. This facilitates forward and reverse driving with left- and right-handed operation, without having to turn your body too far. Speaking of comfort: Drivers love the SXV-CB for its ergonomics, which guarantee fatigue-free load handling. This is

ensured by the comfortable stand-on workplace which offers plenty of space to move, the upholstered backrest, the low step height of 120 mm on each side and the ergonomic steering and operation without needing to alter your hand position. The unrestricted view of the warehouse and load provide a high level of working comfort, as well as safety. After all, where the driver effortlessly has everything in view, driver, surroundings, load and vehicle are kept safe. The robust overhead guard also contributes to safety, while the optionally configurable warning light aids visibility in warehouse traffic. This means that the SXV-CB provides an answer to many common issues in warehouse management and is your powerful and versatile partner for stacking, transportation, order picking, or loading and unloading.

Simply easy

- Fatigue-free operation: precise and smooth electrical steering unit
- Unobstructed view when driving: free view mast and centrally positioned tiller
- Precise control in the narrowest spaces: sensitive proportional valve control and optional creep speed function
- Drive, steer and lift with just one hand: ergonomic and intuitive operation for left and right handers

Simply powerful

- Optimal utilisation of storage space: high lift heights and residual load capacities
- The right driving programme for all situations: outstanding efficiency or maximum handling capacity thanks to ECO, BOOST or Blue-Q
- Maximum handling capacity: powerful, reliable and low-maintenance AC drive motor
- Always ready for use: li-ion battery with a capacity of between 300 Ah and 500 Ah and straightforward lateral battery change

Simply safe

- OptiSpeed tiller adjusts speed automatically depending on the distance between the operator and the truck
- Safety in mind: optional load capacity display shows the operator the current mast height and the corresponding residual load capacity of EXV-CB and EXP
- Safe cornering: Curve Speed Control automatically adjusts speed to the steering angle when cornering

Simply flexible

- For all pallet types: adjustable forks enable handling of a wide range of pallets
- For all load carriers: thanks to the self-supporting forks, closed carriers can also be lifted with ease
- Individually expandable: up to two additional hydraulic functions for attachments

Simply connected

- Manage online: with FleetManager, you can link the forklift truck to a web-based application
- Suitable for multiple operators: define several forklift truck users with different operator profiles
- All trucks under control: fleets can be analysed based on need using comprehensive data
- Information at a glance: modern easy-to-follow colour display



EXV-CB/EXP High Lift Pallet Trucks and SXV-CB Electric Forklift Truck Equipment Variants



		EXV-CB 06	EXV-CB 10/12/16	EXP 14/16/20	SXV-CB 10
General	Display and operating unit with colour display for selection of driving programme	●	●	●	●
	Easy-grip tiller for left and right-handed operators	●	●	●	—
	Electrical steering unit	●	●	●	○
	Additional hydraulic functions for using attachments	○	○	○	○
	Load capacity display	—	—	○	—
	Straddle forks for picking up closed pallets	—	—	●	—
	Mast tilt	—	●	—	○
	High-performance AC drive motor	●	●	●	●
	Cold storage version	○	○	○	—
	Accessory bar	○	○	○	—
	Electric preparation for data terminal	○	○	○	○
	Data transfer via Bluetooth or GPRS	○	○	○	—
	Flashing warning light under overhead guard	○	○	○	○
	Safety Light	○	○	○	○
	One-handed operation	○	○	○	●
	Dual operation	○	○	○	○
	360-degree steering - basic including indicator lights	—	—	—	○
	Mast	Telescopic mast	○	○	○
HiLo mast		○	○	○	○
Triplex mast		○	○	○	○
Mast protective grille		○	○	●	○
Protective mast screen made of polycarbonate		●	●	○	●
Tyres	Load roller tyres, polyurethane, single	—	—	●	—
	Load roller tyres, polyurethane, tandem	●	●	○	—
	Drive wheel for flat surfaces	●	●	●	●
Safety	OptiSpeed-tiller: maximum driving speed controlled by the tiller angle	●	●	●	—
	Curve Speed Control	○	○	○	●
	Access authorisation (key)	●	●	●	●
	Access authorisation (digicode)	○	○	○	—
	FleetManager: access authorisation, shock detection, reports	○	○	○	—
	Silent running and lifting/lowering with vertical tiller	—	—	○	—
	Folding side guard on the left-hand side of the truck	—	—	—	○
	Panoramic mirror inside the vehicle, mounted magnetically	—	—	—	○
Battery	Load backrest	○	○	○	○
	Battery compartment for battery up to 300 Ah	—	—	—	○
	Battery compartment for battery up to 375 Ah	—	●	●	—
	Lateral battery change with roller track	●	●	—	○
	Battery compartment for battery up to 500 Ah	—	○	—	—
	Li-ion battery	—	○	—	○
Built-in charger	—	—	○	—	

● Standard ○ Option — Not available



STILL GmbH
Berzeliusstr. 10
22113 Hamburg
Germany
Tel.: +49 40 73 39 20 00
Fax: +49 40 73 39 20 01
info@still.de

For further information please visit
www.still.eu

STILL is certified in the following areas: Quality management, occupational safety, environmental protection and energy management.



first in intralogistics