



MOVING YOU FURTHER

180D-9



Some of the photos may include optional equipment

Your satisfaction is our priority.

Proven technology! Hyundai 9 Series diesel forklift

The Hyundai 9 Series big diesel truck is ready for the customers. Overwhelming the worksite with its superior performance and providing optimal fuel efficiency, the Hyundai 9 Series big diesel truck offers outstanding durability based on its application of high-quality hydraulic and functional components suitable for large and heavy load duties, as well as comfortable and pleasant driving space, and convenient after-sales management.

Excellent performance

- Eco-friendly, powerful, 285PS Benz OM936 engine
- Fully automatic ZF electronic transmission with 3 forward-reverse shifts
- Wet disc brake & Kessler drive axle with planetary final reduction gears
- 3-stage TS mast (OPT)

Ensured safety at the logistics site

- Auto parking brake
- Real-time notification of rear wheel steering angle
- Operator presence sensing system (OPSS)
- Speed limit setting

Comfortable and safe driving

- Deluxe cabin equipped with fully automatic air conditioning
- Hydraulic pilot valve lever
- Load weight indicator
- Password starting system

Convenient management

- One-touch electric motor-driven tilting cabin
- Notification of replacement of the consumable items
- Engine fault diagnosis





Power & Performance

High Efficiency, Optimal Performance

Robust, refined, and luxurious design – 180D-9!
Offering increased power and fuel economy,
this model will be your best partner in
any work environment.



Some of the photos may include optional equipment



6-cylinder turbocharger of Mercedes Benz

OM936 engine consumes much less fuel and ensures excellent accelerating ability and durability compared to the existing model. In addition, a fuel recirculation kit is included to enable quick warming up and prevent the fuel filter clogging caused by paraffin separation. The Selective Catalytic Reduction (SCR) system allows easy emissions control. (Injection of urea solution required)



•285PS/2,200rpm •117kgf.m/1,500rpm

Gradeability and travel speed

With the best engine power, it delivers outstanding running performance and exceptional gradeability, ensuring stable operation at high speeds, on rough terrains and slopes.

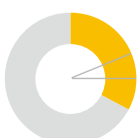

33% (18.3°)

Max. Gradeability (Loaded)



38.4km/h

Max. Travel Speed (Unloaded)



ZF Full-automatic transmission

Due to optimized engine and performance of the transmission, acceleration performance in low-speed sections has improved and noise, heat generation has reduced. Also, it is possible to check the transmission status/failure etc. on the display window of the cluster.



Drive axle & Wet disc brake

Kessler's high capacity drive axle, the planetary gear type, enables outstanding power transmission and shows exceptional adaptability to sudden changes in torque. Also, wet-type multi-plate service brake delivers consistent braking power when operations are repeated.



Hydraulic steering axle

The hydraulic steering system always guarantees smooth and flexible steering, preventing over-run and kick-back. Taper roller bearings and ADI knuckles with excellent strength and wear resistance are used in consideration of heavy load operation. The newly added protector prevents damage of rear wheel hub bolts.

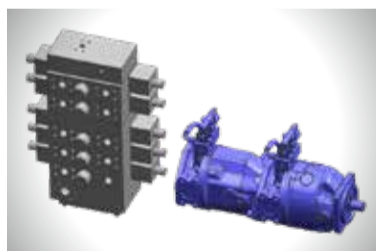

Load sensing hydraulic system

Hydraulic system consisting of a Bosch's swash plate piston pump and control valve optimizes energy consumption and increases durability of engine and transmission.

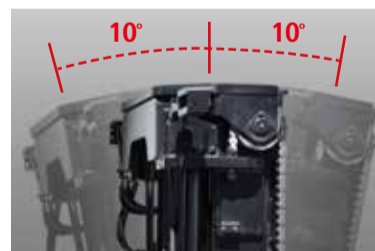

Mast Tilting Angle

Tilting speed is improved by combining some hydraulic pressure generated from the secondary pump to the primary pump flow rate. The tilting angle of 10 degrees forward and 10 degrees backward increases work efficiency.

Engine mode control

Engine performance can be adjusted to suit the workload, simply by operating a switch mounted on the side panel.
STD mode : Light load operations (fuel saving mode)
PWR mode : Operations on slope Requiring intense power

Low engine RPM conversion

Depending on the need, the driver can convert the engine to a low RPM. The RPM will return to its initial settings value once engine is stopped and restarted.

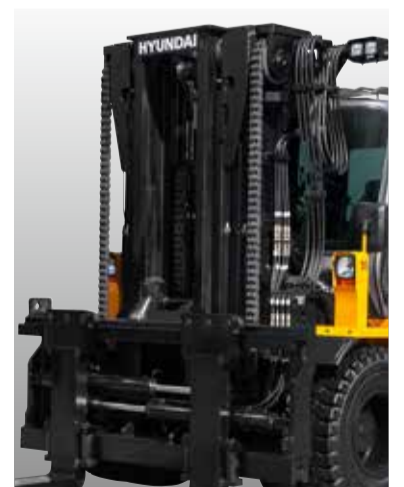

3-stage T/S mast for high lifting (OPT)

This model provides 3-stage masts of 7 types with lifting height of 4.6~7.0m, suitable for the indoor working conditions. Also, the removable free lift cylinder (first cylinder) provides wider visibility.



Easy & Comfort

Comfortable Workspace Intuitive Monitoring

Ergonomically designed workspace for operator provides the best comfort in any type of operation.



Some of the photos may include optional equipment

Ergonomic operating space

The ergonomically designed cabin was made for more space, a wider field of view and operator comfort. The smooth lever and pedal operation, adjustable tilting handle, suspension seat and deluxe cabin provide comfortable and efficient operation.



Full air suspension seat (OPT)

Ergonomically designed to support a comfortable posture, the full suspension seat relieves fatigue and enables greater comfort for operation.

New style & centralized cluster

The TFT LCD color monitor indicates real-time driving information and changing vehicle stability depending on the work condition, thus allowing easy and efficient control for the operator. Diagnostic error codes ensure easy trouble-shooting and the operator can select various performance modes.



Main Functions

- Urea level gauge
- T/M information display
- Parking brake indicator
- Battery charging failure warning
- Brake system overheat warning
- Air cleaner filter warning
- Machine inclination warning
- Load weight indicator
- Steering wheel position
- Engine coolant temperature warning
- Engine check warning lamp
- Seatbelt warning
- Exchange consumable indicator
- Mast tilt angle indicator
- High beam indicator
- T/M error warning
- OPSS indicator
- Inching indicator



Fully automatic air-conditioner

The air-conditioner automatically adjusts temperature to the set temperature and provides more comfortable working environment for the operator.



Ergonomic pedals

The high-quality floor mat and ergonomically designed pedal arrangement reduce operator fatigue and drastically improve productivity.



Responsive levers

Responsive levers with the latest hydraulic system enables micromanipulation and excellent performance.
(5-Lever, 6-Function : STD / 7-Function : OPT)

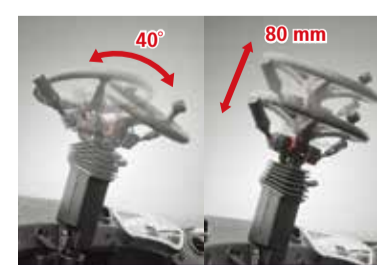

Adjustable steering wheel

The steering wheel can be pushed forward or backward, pushed in or out to suit the driver's body shape, providing an all the more comfortable work environment.



Integrated communications controller

Cutting-edge communications technology enhances the operator convenience (Bluetooth hands-free, cellphone call, radio communication, USB/MP3 audio control functions).



Secure & Safety

Excellent visibility Advanced safety

The safely designed driver's space makes your operating more comfortable.

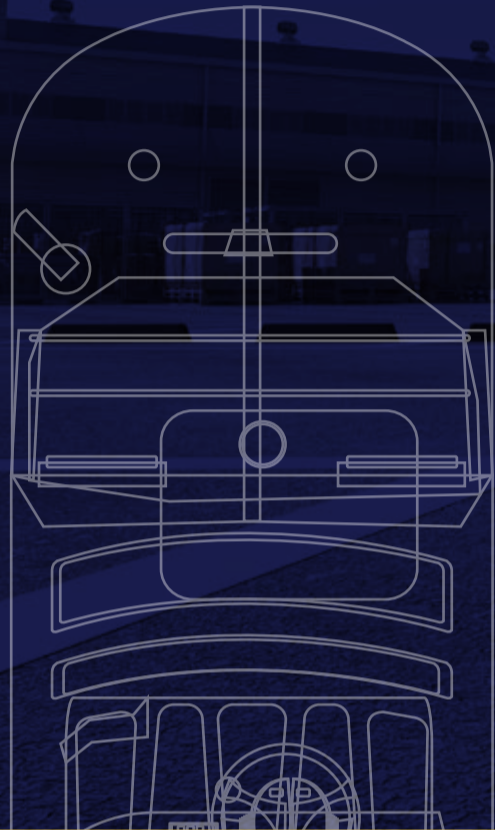

EXCELLENT VISIBILITY

Some of the photos may include optional equipment

Excellent visibility for safe operation

Optimized lift cylinder arrangement provides the operator with wider visibility. A panoramic mirror expands the driver's rear view.



Some of the photos may include optional equipment

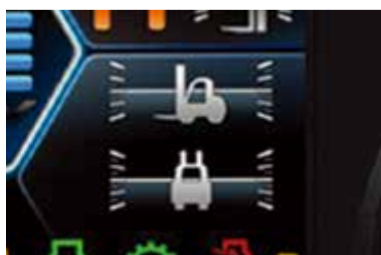

Machine inclination warning system

The grade (left) and slope (right) sensors are built into the MCU and provide the grade and slope status information of the vehicle connected with the road surface condition in real time. Also, an alarm is emitted when the KS regulation is exceeded.



Steering wheel angle

As a measurement of the steering angle sensor, which is installed on the kingpin of the rear axle, is displayed on the large cluster screen as an image, the operator can predict the direction of the vehicle without difficulty.

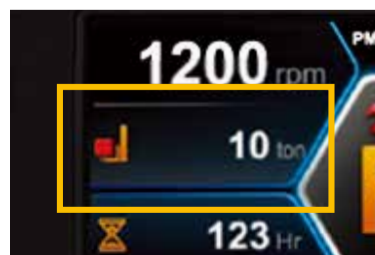

Load weight indicator (OPT)

When lifting a load, a change in hydraulic pressure of the lift line is converted to a measurement of weight displayed in real time, and a warning is given at the time of overload.

Safety features

The adoption of a high-sensitivity sensor and advanced safety system eliminates the risk of safety accidents.



Auto parking brake

If the operator leaves the seat while the gear lever is in neutral, the parking brake is automatically engaged to secure safety, and released upon the operator's return to the seat.

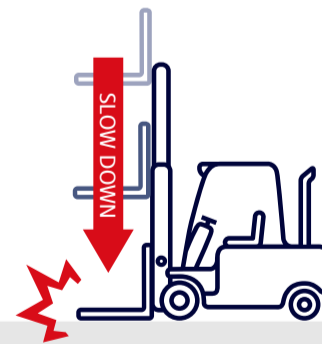

Fork Safety Features

The down-safety valve prevents forks from dropping down in case of sudden damage of hydraulic line.

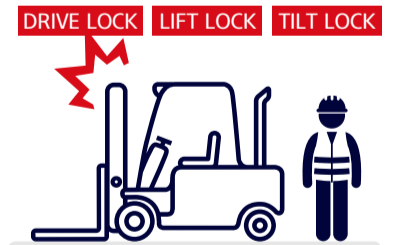

Operator presence sensing system

All mast and drive movements stop functioning when the operator is not in the seat.

Speed limit setting

The operator can set and limit the maximum speed from 10km/h to 30km/h.

Password starting system

The operator can set a password to prevent vehicle theft and possible safety accidents in case the vehicle is used by an unauthorized person. (Up to 10 passwords can be set.)



Increased night work efficiency

Four work lamps on the upper side of the mast, two headlamps on the frame fender, and two work lamps on the upper side of the counterweight enable efficient nighttime and indoor operations.



Maintenance & Convenience

Fast and Easy Maintenance & Convenience Features

An ideal arrangement of components ensures easy access and convenience for maintenance.

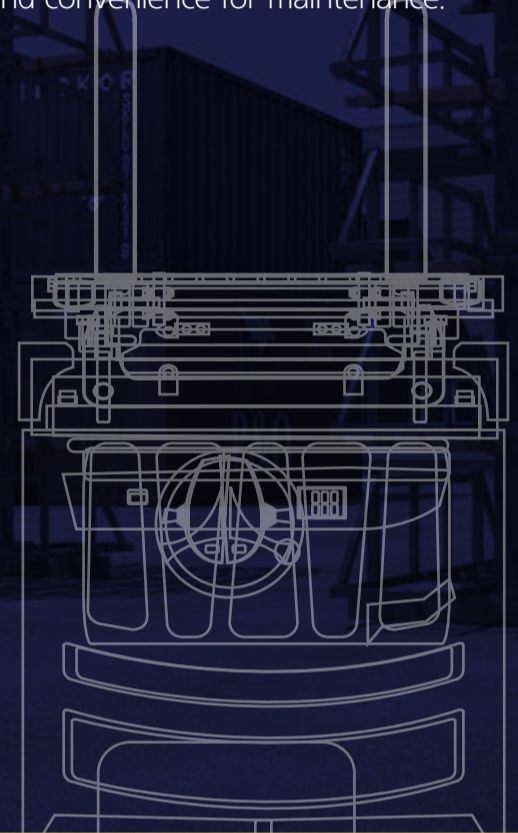

Some of the photos may include optional equipment

Fully opening tilting cabin and hood

The tilting cabin that has been dramatically improved in its maintainability functions with a separate electric motor and hydraulic pump. By opening the cabin, which can be tilted to a maximum of 54 degrees, and the engine hood, which can be opened to the left or right, all functional components installed inside the chassis can easily be examined and serviced.



Some of the photos may include optional equipment



Rear view camera (OPT)

A rear view camera and monitor are linked to the reverse gear, ensuring safer rear work environment.

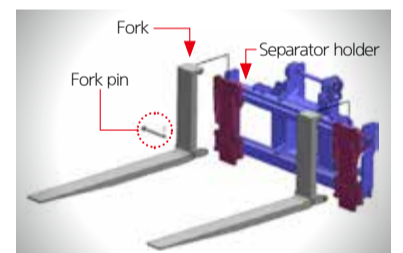

Separator holder carriage (OPT)

To improve handling and easily switch forks and other attachment, separator holder system is adopted as option. It is possible to install various attachments easily.



Up-to-date cooling system

Variable speed and remote controlled fans reduce fuel consumption and noise, while the aluminum cooler improves durability and heat output.



Battery master switch

Damage is prevented during inspection/maintenance of electronic units, and battery discharge.



Convenient air cleaner

Air cleaner with large capacity enables longer filter life span. The operator can access the air filter easily by simply opening the engine hood.



Cabin air cleaner filter

The air cleaner filter blocks external dust and noise from the cabin, and continuously supplies clean air indoor to maintain fresh air in the driving space.



Automatic tilting system

The cabin tilting system allows the operator to tilt the cabin with a single switch up to 54 degrees, thus enabling easy maintenance of functional devices located under the driver seat.



Engine fault diagnosis

Details of engine fault diagnosed by the engine control unit (ECU) can be checked on the cluster.



Maintenance management

Replacement cycle of consumable items can be checked on the monitor, thus preventing performance deterioration of major functional parts due to failure to notice deterioration.

Mast specifications



Mast type	Maximum fork height	Overall mast height (lowered)	Tilting Angle Fwd / Bwd	Load capacity (900mm LC)	Truck weight (unloaded)	
		mm	deg	kg	kg	
2-stage standard mast	V300	3,020	3,200	10 / 10	18,000	25,966
	※V330	3,320	3,350	10 / 10	18,000	26,094
	V350	3,520	3,450	10 / 10	18,000	26,170
	V400	4,020	3,700	10 / 10	18,000	26,541
	V450	4,520	3,950	10 / 10	18,000	26,687
	V500	5,020	4,200	10 / 10	18,000	27,064
	V550	5,520	4,450	10 / 10	18,000	27,278
	V600	6,020	4,700	10 / 10	18,000	27,493
	V650	6,520	4,950	10 / 10	18,000	27,690
3-stage standard mast	V700	7,020	5,200	10 / 10	18,000	27,880
	TS460	4,634	2,950	10 / 10	18,000	27,350
	TS508	5,084	3,100	10 / 10	18,000	27,522
	TS538	5,384	3,200	10 / 10	18,000	27,693
	TS568	5,684	3,300	10 / 10	18,000	27,785
	TS600	6,044	3,420	10 / 10	18,000	27,922
	TS658	6,584	3,600	10 / 10	18,000	28,116
TS700	7,034	3,750	10 / 10	18,000	28,265	

※ : Standard

Load Capacity

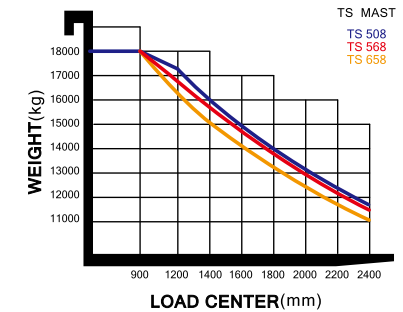
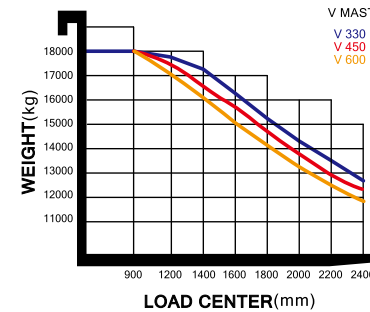

Optional Items



- Fork(mm) : 100 x 250 x 2,450(STD) / 100 x 250 x 2,000 / 100 x 250 x 3,150
- Separator holder carriage
- Under Cover
- Seat : Seat heater (STD), Leather + Seat heater, Air suspension + Seat heater

Specification



Identification	Load capacity	kg	18,000
	Load center	mm	900
	Maximum lift height ①	mm	3,320
	Lift speed, loaded/ unloaded	mm/sec	370 / 420
	Lowering speed, loaded/unloaded	mm/sec	420 / 300
	Fork dimension, l x w x h	mm	2,450 x 250 x 100
	Fork carriage width ⑭	mm	2,950
	Tilting angle (forward ② / backward ③)	degree°	10 / 10
	Extended height ④ / Lowered height ⑤	mm	4,960 / 3,350
	Travel speed, unloaded	km/hr	38.4
Basic Dimensions	Max. Gradeability, loaded	%(°)	33 (18.3)
	Min. Turning Radius ⑥	mm	5,220
	Max. Drawbar pull, loaded	KN	150
	Service weight	kg	26,094
	Length to face of forks ⑦ / Overall width ⑧	mm	5,595 / 2,540
	Height of overhead guard (cabin) ⑨	mm	2,990
Engine	Ground clearance ⑩ / Wheel base ⑪	mm	245 / 3,750
	Tread (front ⑫ / rear ⑬)	mm	1,860 / 2,300
	Tires (front / rear)	-	12.00-20-20PR
	Manufacturer / Model	-	BENZ (MTU)
	Engine power acc. to ISO 1585	kW/rpm	210 / 2,200
	Max. Torque	kgf·m/rpm	117 / 1,500
	Displacement	cc	7,700

Dimension

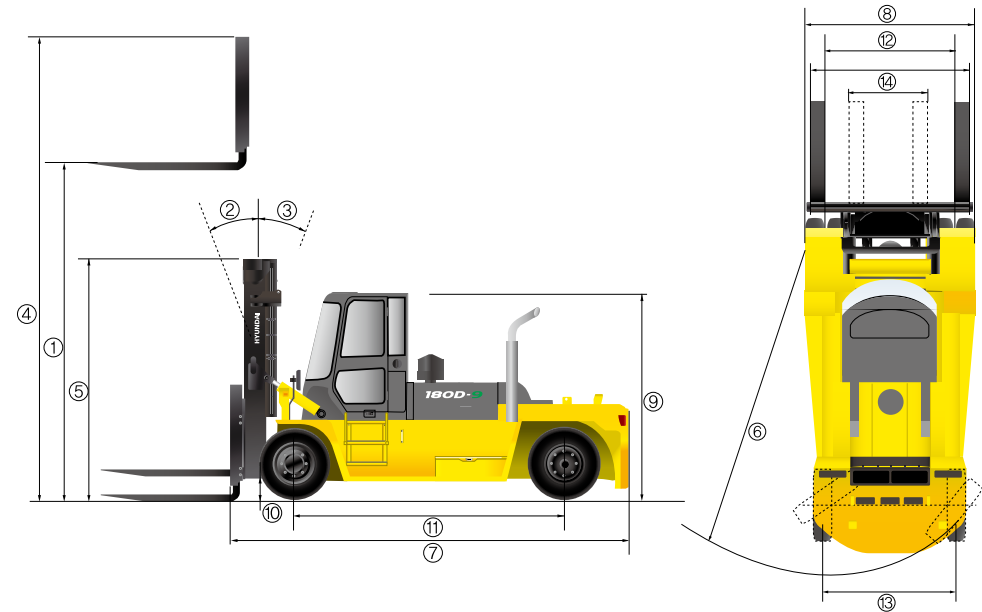

* Some of the data may change depending on optional equipment.